



US006877254B2

(12) **United States Patent**
Ellis, III

(10) **Patent No.:** **US 6,877,254 B2**
(45) **Date of Patent:** ***Apr. 12, 2005**

(54) **CORRECTIVE SHOE SOLE STRUCTURES USING A CONTOUR GREATER THAN THE THEORETICALLY IDEAL STABILITY PLANE**

(52) **U.S. Cl.** 36/25 R; 36/30 R; 36/31; 36/88; 36/114

(58) **Field of Search** 36/32 R, 25 R, 36/30 R, 31, 114, 88, 91, 28, 163, 116, 11.5, 11

(75) **Inventor:** **Frampton E. Ellis, III**, Arlington, VA (US)

(56) **References Cited**

(73) **Assignee:** **Anatomic Research, Inc.**, Jasper, FL (US)

U.S. PATENT DOCUMENTS

(*) **Notice:** Subject to any disclaimer, the term of this patent is extended or adjusted under 35 U.S.C. 154(b) by 0 days.

193,914 A 8/1877 Berry
280,791 A 7/1883 Brooks

(Continued)

This patent is subject to a terminal disclaimer.

FOREIGN PATENT DOCUMENTS

AT 200963 5/1958
CA 1 138 194 12/1982

(Continued)

(21) **Appl. No.:** **10/294,023**

OTHER PUBLICATIONS

(22) **Filed:** **Nov. 13, 2002**

Williams, "Walking on Air," *Case Alumnus*, Fall 1989, vol. LXVII, No. 6, pp. 4-8.

(65) **Prior Publication Data**

Brooks advertisement, *Runner's World*, Jun. 1989, p. 56+3pp.

US 2003/0079375 A1 May 1, 2003

(Continued)

Related U.S. Application Data

(63) Continuation of application No. 08/482,838, filed on Jun. 7, 1995, now Pat. No. 6,675,498, which is a continuation of application No. 08/452,490, filed on May 30, 1995, now Pat. No. 6,360,453, which is a continuation of application No. 08/162,962, filed on Dec. 8, 1993, now Pat. No. 5,544,429, which is a continuation of application No. 08/142,120, filed on Oct. 28, 1993, now abandoned, which is a continuation of application No. 07/930,469, filed on Aug. 20, 1992, now Pat. No. 5,317,819, which is a continuation of application No. 07/830,747, filed on Feb. 7, 1992, now abandoned, which is a continuation-in-part of application No. 07/492,360, filed on Mar. 9, 1990, now Pat. No. 4,989,349, said application No. 08/482,838, is a continuation of application No. 07/239,667, filed on Sep. 2, 1988, now abandoned, which is a continuation of application No. 07/219,387, filed on Jul. 15, 1988, now abandoned.

Primary Examiner—Anthony Stashick

(74) *Attorney, Agent, or Firm*—Knoble Yoshida & Dunleavy, LLC

(57) **ABSTRACT**

A shoe having a sole contour which follows a theoretically ideal stability plane as a basic concept, but which deviates, outwardly therefrom to provide greater than natural stability. Thickness variations outwardly from the stability plane are disclosed, along with density variations to achieve a similar greater than natural stability.

(51) **Int. Cl.**⁷ A43B 13/14

22 Claims, 8 Drawing Sheets

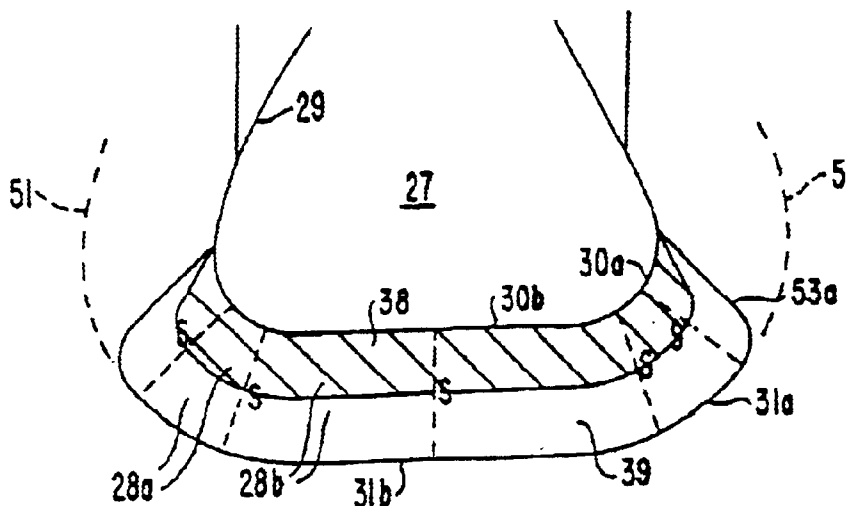

U.S. PATENT DOCUMENTS

288,127 A	11/1883	Shepard	4,235,026 A	11/1980	Plagenhoef
500,385 A	6/1893	Hall	4,237,627 A	12/1980	Turner
532,429 A	1/1895	Rogers	4,240,214 A	12/1980	Sigle et al.
584,373 A	6/1897	Kuhn	4,241,523 A	12/1980	Daswick
1,283,335 A	10/1918	Shillcock	4,245,406 A	1/1981	Landay et al.
1,289,106 A	12/1918	Bullock	4,250,638 A	2/1981	Linnemann
D55,115 S	5/1920	Barney	4,258,480 A	3/1981	Famolare, Jr.
1,458,446 A	6/1923	Shaeffer	4,259,792 A	4/1981	Halberstadt
1,622,860 A	3/1927	Cutler	4,262,433 A	4/1981	Hagg et al.
1,639,381 A	8/1927	Manelas	4,263,728 A	4/1981	Frecentese
1,701,260 A	2/1929	Fischer	4,266,349 A	5/1981	Schmohl
1,735,986 A	11/1929	Wray	4,268,980 A	5/1981	Gudas
1,853,034 A	4/1932	Bradley	4,271,606 A	6/1981	Rudy
1,870,751 A	8/1932	Reach	4,272,858 A	6/1981	Hlustik
2,120,987 A	6/1938	Murray	4,274,211 A	6/1981	Funck
2,124,986 A	7/1938	Pipes	4,297,797 A	11/1981	Meyers
2,155,166 A	4/1939	Kraft	4,302,892 A	12/1981	Adamik
2,162,912 A	6/1939	Craver	4,305,212 A	12/1981	Coomer
2,170,652 A	8/1939	Brennan	4,308,671 A	1/1982	Bretschneider
2,179,942 A	11/1939	Lyne	4,309,832 A	1/1982	Hunt
D119,894 S	4/1940	Sherman	4,314,413 A	2/1982	Dassier
2,201,300 A	5/1940	Prue	4,316,332 A	2/1982	Giese et al.
2,206,860 A	7/1940	Sperry	4,316,335 A	2/1982	Giese et al.
D122,131 S	8/1940	Sannar	4,319,412 A	3/1982	Muller et al.
D128,817 S	8/1941	Esterson	D264,017 S	4/1982	Turner
2,251,468 A	8/1941	Smith	4,322,895 A	4/1982	Hockerson
2,328,242 A	8/1943	Witherill	D265,019 S	6/1982	Vernonet
2,345,831 A	4/1944	Pierson	4,335,529 A	6/1982	Badalamenti
2,433,329 A	12/1947	Adler et al.	4,340,626 A	7/1982	Rudy
2,434,770 A	1/1948	Lutey	4,342,161 A	8/1982	Schmohl
2,470,200 A	5/1949	Wallach	4,348,821 A	9/1982	Daswick
2,627,676 A	2/1953	Hack	4,354,319 A	10/1982	Block et al.
2,718,715 A	9/1955	Spilman	4,361,971 A	12/1982	Bowerman
2,814,133 A	11/1957	Herbst	4,366,634 A	1/1983	Giese et al.
3,005,272 A	10/1961	Shelare et al.	4,370,817 A	2/1983	Ratanangsu
3,100,354 A	8/1963	Lombard et al.	4,372,059 A *	2/1983	Ambrose
3,110,971 A	11/1963	Chang	4,398,357 A	8/1983	Batra
3,305,947 A	2/1967	Kal soy	4,399,620 A	8/1983	Funck
3,416,174 A	12/1968	Novitske	D272,294 S	1/1984	Watanabe
3,512,274 A	5/1970	McGrath	4,449,306 A *	5/1984	Cavanagh
3,535,799 A	10/1970	Onitsuka	4,451,994 A	6/1984	Fowler
3,806,974 A	4/1974	Di Paolo	4,454,662 A	6/1984	Stubblefield
3,824,716 A	7/1974	Di Paolo	4,455,765 A	6/1984	Sjöswärd
3,863,366 A	2/1975	Auberry et al.	4,468,870 A	9/1984	Sternberg
3,958,291 A	5/1976	Spier	4,484,397 A	11/1984	Curley, Jr.
3,964,181 A *	6/1976	Holcombe, Jr.	4,494,321 A	1/1985	Lawlor
3,997,984 A	12/1976	Hayward	4,505,055 A	3/1985	Bergmans
4,003,145 A	1/1977	Liebscher et al.	4,506,462 A	3/1985	Cavanagh
4,030,213 A	6/1977	Daswick	4,521,979 A	6/1985	Blaser
4,043,058 A	8/1977	Hollister et al.	4,527,345 A *	7/1985	Lopez Lopez
4,068,395 A	1/1978	Senter	D280,568 S	9/1985	Stubblefield
4,083,125 A	4/1978	Benseler et al.	4,542,598 A *	9/1985	Misevich et al.
4,096,649 A	6/1978	Saurwein	4,546,559 A *	10/1985	Dassler
4,098,011 A	7/1978	Bowerman et al.	4,557,059 A *	12/1985	Misevich et al.
4,128,950 A	12/1978	Bowerman et al.	4,559,723 A *	12/1985	Hamy et al.
4,128,951 A	12/1978	Tansill	4,559,724 A *	12/1985	Norton
4,141,158 A	2/1979	Benseler et al.	4,561,195 A *	12/1985	Onoda et al.
4,145,785 A	3/1979	Lacey	4,577,417 A *	3/1986	Cole
4,149,324 A	4/1979	Lesser et al.	4,578,882 A *	4/1986	Talarico, II
4,161,828 A	7/1979	Benseler et al.	4,580,359 A *	4/1986	Kurrash et al.
4,161,829 A	7/1979	Wayser	4,624,061 A *	11/1986	Wezel et al.
4,170,078 A	10/1979	Moss	4,624,062 A *	11/1986	Autry
4,183,156 A	1/1980	Rudy	4,641,438 A *	2/1987	Laird et al.
4,194,310 A	3/1980	Bowerman	4,642,917 A *	2/1987	Ungar
D256,180 S	8/1980	Turner	4,651,445 A *	3/1987	Hannibal
D256,400 S	8/1980	Famolare, Jr.	D289,341 S	4/1987	Turner
4,217,705 A	8/1980	Donzis	4,670,995 A *	6/1987	Huang
4,219,945 A	9/1980	Rudy	4,676,010 A *	6/1987	Cheskin
4,223,457 A	9/1980	Borgeas	4,694,591 A	9/1987	Banich et al.
4,227,320 A	10/1980	Borgeas	4,697,361 A *	10/1987	Ganter et al.
			D293,275 S *	12/1987	Bua

4,724,622 A * 2/1988 Mills
 D294,425 S * 3/1988 Le
 4,727,660 A * 3/1988 Bernhard
 4,730,402 A * 3/1988 Norton et al.
 4,731,939 A * 3/1988 Parracho et al.
 4,747,220 A * 5/1988 Autry et al.
 D296,149 S * 6/1988 Diaz
 D296,152 S * 6/1988 Selbiger
 4,754,561 A * 7/1988 Dufour
 4,756,098 A * 7/1988 Boggia
 4,757,620 A * 7/1988 Tiitola
 4,759,136 A * 7/1988 Stewart et al.
 4,768,295 A * 9/1988 Ito
 4,769,926 A 9/1988 Meyers
 D298,684 S 11/1988 Pitchford
 4,785,557 A * 11/1988 Kelley et al.
 4,817,304 A * 4/1989 Parker et al.
 4,827,631 A 5/1989 Thornton
 4,833,795 A 5/1989 Diaz
 4,837,949 A 6/1989 Dufour
 D302,900 S 8/1989 Kolman et al.
 4,854,057 A 8/1989 Misevich et al.
 4,858,340 A * 8/1989 Pasternak
 4,866,861 A 9/1989 Noone
 4,876,807 A 10/1989 Tiitola et al.
 4,890,398 A 1/1990 Thomasson
 4,894,933 A 1/1990 Tonkel et al.
 4,897,936 A 2/1990 Fuerst
 4,906,502 A 3/1990 Rudy
 4,922,631 A 5/1990 Anderie
 4,934,070 A 6/1990 Mauger
 4,934,073 A 6/1990 Robinson
 D310,131 S 8/1990 Hase
 D310,132 S 8/1990 Hase
 4,947,560 A 8/1990 Fuerst et al.
 4,949,476 A 8/1990 Anderie
 D310,906 S 10/1990 Hase
 4,982,737 A 1/1991 Guttman
 D315,634 S 3/1991 Yung-Mao
 5,010,662 A 4/1991 Dabuzhsky et al.
 5,014,449 A 5/1991 Richard et al.
 5,024,007 A 6/1991 DuFour
 5,025,573 A 6/1991 Giese et al.
 D320,302 S 10/1991 Kiyosawa
 5,052,130 A 10/1991 Barry et al.
 5,077,916 A 1/1992 Beneteau
 5,079,856 A 1/1992 Truelsen
 5,092,060 A 3/1992 Frachey et al.
 D327,164 S 6/1992 Hatfield
 D327,165 S 6/1992 Hatfield
 5,131,173 A 7/1992 Anderie
 D328,968 S 9/1992 Tinker
 D329,528 S 9/1992 Hatfield
 D329,739 S 9/1992 Hatfield
 D330,972 S 11/1992 Hatfield et al.
 D332,344 S 1/1993 Hatfield et al.
 D332,692 S 1/1993 Hatfield et al.
 5,191,727 A 3/1993 Barry et al.
 5,224,280 A 7/1993 Preman et al.
 5,224,810 A 7/1993 Pitkin
 5,237,758 A 8/1993 Zachman
 D347,105 S 5/1994 Johnson
 5,369,896 A 12/1994 Frachey et al.
 D372,114 S 7/1996 Tunre et al.
 5,543,194 A 8/1996 Rudy
 5,572,805 A 11/1996 Giese et al.
 D388,594 S 1/1998 Turner et al.
 D409,362 S 5/1999 Turner et al.
 D409,826 S 5/1999 Tuner et al.
 D410,138 S 5/1999 Turner et al.
 5,909,948 A 6/1999 Ellis, III

6,115,941 A 9/2000 Ellis, III
 6,115,945 A 9/2000 Ellis, III
 6,163,982 A 12/2000 Ellis, III
 D444,293 S 7/2001 Turner et al.
 D450,916 S 11/2001 Turner et al.

FOREIGN PATENT DOCUMENTS

CA	1 176 458	10/1984
DE	B23257 VII/71a	5/1956
DE	1 888 119	2/1964
DE	1918131	6/1965
DE	1918132	6/1965
DE	1 287 477	1/1969
DE	2036062	7/1970
DE	1948620	5/1971
DE	1685293	7/1971
DE	1 685 260	10/1971
DE	2045430	3/1972
DE	2522127	11/1976
DE	2525613	12/1976
DE	2602310	7/1977
DE	2613312	10/1977
DE	27 06 645	8/1978
DE	2654116	1/1979
DE	27 37 765	3/1979
DE	28 05 426	8/1979
DE	3021936	4/1981
DE	30 24 587 A1	1/1982
DE	8219616.8	9/1982
DE	3113295	10/1982
DE	32 45 182	5/1983
DE	33 17 462	10/1983
DE	831831.7	12/1984
DE	3347343	7/1985
DE	8530136.1	2/1988
DE	36 29 245	3/1988
EP	0 048 965	4/1982
EP	0 069 083	1/1983
EP	0 083 449	7/1983
EP	0 130 816	1/1985
EP	0 185 781	7/1986
EP	0207063	10/1986
EP	0 206 511	12/1986
EP	0 213 257	3/1987
EP	0 215 974	4/1987
EP	0 238 995	9/1987
EP	0 260 777	3/1988
EP	0 301 331	2/1989
EP	0 329 391	8/1989
EP	0 410 087	1/1991
FR	602.501	3/1926
FR	925.961	9/1947
FR	1.004.472	3/1952
FR	1245672	10/1960
FR	1.323.455	2/1963
FR	2 006 270	11/1971
FR	2 261 721	9/1975
FR	2 511 850	3/1983
FR	2 622 411	5/1989
GB	16143	of 1892
GB	9591	of 1913
GB	764956	1/1957
GB	807305	1/1959
GB	1504615	3/1978
GB	2 023 405	1/1980
GB	2 039 717	8/1980
GB	2076633	12/1981
GB	2133668	8/1984
GB	2 136 670	9/1984
JP	39-15597	8/1964
JP	45-5154	3/1970

JP	50-71132	11/1975
JP	57-139333	8/1982
JP	59-23525	7/1984
JP	61-55810	4/1986
JP	1129505	6/1986
JP	61-167810	10/1986
JP	1-195803	8/1989
JP	2136505	5/1990
JP	2279103	11/1990
JP	3-85102	4/1991
JP	3086101	4/1991
JP	4-279102	10/1992
JP	5-123204	5/1993
NZ	189890	9/1981
WO	WO8707481	12/1987
WO	WO 91/10377	7/1991
WO	WO 91/11124	8/1991
WO	WO 91/11924	8/1991
WO	WO 91/19429	12/1991
WO	WO 92/07483	5/1992
WO	WO 92/18024	10/1992
WO	WO 93/13928	7/1993
WO	WO 94/03080	2/1994
WO	WO 97/00029	1/1997
WO	WO 00/64293	11/2000

OTHER PUBLICATIONS

German description of adidas badminton shoe (top row, left), pre-1989(?).

Nigg et al., "Influence of Heel Flare and Midsole Construction on Pronation, Supination, and Impact Forces for Heel-Toe Running," *International Journal of Sport Biomechanics*, 1988, vol. 4, No. 3, pp. 205-219.

Nigg et al., "The influence of lateral heel flare of running shoes on pronation and impact forces," *Medicine and Science in Sports and Exercise*, © 1987, vol. 19, No. 3, pp. 294-302.

The Reebok Lineup, Fall 1987, 2 pages.

Cavanagh et al., "Biological Aspects of Modeling Shoe/Foot Interaction During Running," *Sport Shoes and Playing Surfaces: Biomechanical Proper ties*, Champaign, IL, © 1984, pp. 24-25, 32-35, and 46-47.

Blechs Schmidt, "The Structure of the Calcaneal Padding," *Foot & Ankle*, © 1982, Official Journal of the American Orthopaedic Foot Society, Inc., pp. 260-283.

Cavanagh, *The Running Shoe Book*, Mountain View, CA, © 1980, pp. 176-180.

Ellis, III, *Executive Summary*, two pages with Figures I-VII attached.

Originally filed specification for U.S. Appl. No. 08/648,792, filed Aug. 28, 2000.

Originally filed specification for U.S. Appl. No. 08/462,531, filed Jun. 5, 1995.

Originally filed specification for U.S. Appl. No. 08/473,212, filed Jun. 7, 1995.

Originally filed specification for U.S. Appl. No. 08/477,640, filed Jun. 7, 1995.

Originally filed specification for U.S. Appl. No. 08/033,468, filed Mar. 18, 1993.

Originally filed specification for U.S. Appl. No. 08/452,490, filed May 30, 1995, and 08/473,974 filed Jun. 7, 1995.

Originally filed specification for U.S. Appl. No. 08/479,776, filed Jun. 7, 1995.

Originally filed specification for U.S. Appl. No. 09/908,688, filed Jul. 20, 2001.

Johnson et al., << A Biomechanical Approach to the Design of Football Boots >>, *Journal of Biomechanics*, vol. 9, pp. 581-585 (1976).

Fixx, *The Complete Book of Running*, pp 134-137 1977.

Romika Catalog, Summer 1978.

World Professional Squash Association Pro Tour Program, 1982-1983.

Williams et al., << The Mechanics of Foot Action During The GoldSwing and Implications for Shoe Design >>, *Medicine and Science in Sports and Exercise*, vol. 15, No. 3, pp 247-255 1983.

Nigg et al., << Biomechanical Aspects of Sport Shoes and Playing Surfaces >>, *Proceedings of the International Symposium on Biomechanical Aspects of Sport Shoes and Playing Surfaces*, 1983.

Valiant et al., << A Study of Landing from a Jump : Implications for the Design of a Basketball Shoe >>, *Scientific Program of IX Internatioanl Congress of Biomechanics*, 1983.

Frederick, *Sports Shoes and Playing Surfaces, Biomechanical Properties*, Entire Book, 1984.

Saucony Spot-bilt Catalog Supplement, Spring 1985.

Adidas shoe, Model << Fire >> 1985.

Adidas shoe, Model "Tolio H.", 1985.

Adidas shoe, Model "Buffalo" 1985.

Adidas shoe, Model, "Marathon 86" 1985.

Adidas shoe, Model << Boston Super >> 1985.

Leuthi et al., << Influence of Shoe Construction on Lower Extremity Kinematics and Load During Lateral Movements In Tennis >>, *International Journal of Sport Biomechanics*, , vol. 2, pp 166-174 1986.

Nigg et al., *Biomechanics of Running Shoes*, entire book, 1986.

Runner's World, Oct. 1986.

AVIA Catalog 1986.

Brooks Catalog 1986.

Adidas Catalog 1986.

Adidas shoe, Model << Questar >>, 1986.

Adidas shoe, Model "London" 1986.

Adidas shoe, Model << Marathon >> 1986.

Adidas shoe, Model << Kingscup Indoor >>, 1986.

Komi et al., "Interaction Between Man and Shoe in Running: Considerations for More Comprehensive Measurement Approach", *International Journal of Sports Medicine*, vol. 8, pp. 196-202 1987.

Nigg, << Biomechanical Analysis of Ankle and Foot Movement >> *Medicine and Sport Science*, vol. 23, pp 22-29 1987.

Adidas Catalog, Spring 1987.

Nike Fall Catalog 1987, pp 50-51.

Footwear Journal, Nike Advertisement, Aug. 1987.

Sporting Goods Business, Aug. 1987.

Vagenas et al., << Evaluationm of Rearfoot Asymmetrics in Running With Worn and New Running Shoes << , *International Journal of Sport Biomechanics*, vol., 4, No. 4, pp 220-230 (1988).

Nawoczenside et al., << Effect of Rocker Sole Design on Plantar Forefoot Pressures >> *Journal of the American Podiatric Medical Association*, vol. 79, No. 9, pp 455-460, 1988.

Srts Illustrated, Special Preview Issue, The Summer Olympics << Seoul '88 >> Reebok Advertistement.

Sports Illustrated, Nike Advertisement, Aug. 8, 1988.

Runner's World, "Shoe Review" Nov. 1988 pp 46-74.

- Footwear News, Special Supplement, Feb. 8, 1988.
 Footwear New, vol. 44, No. 37, Nike Advertisement (1988).
 Saucony Spot-bilt Catalog 1988.
 Runner's World, Apr. 1988.
 Kronos Catalog, 1988.
 Avia Fall Catalog 1988.
 Nike shoe, Model << High Jump 88 >>, 1988.
 Nike Catalog, Footwear Fall, 1988.
 Adidas Catalog 1988.
 Segesser et al., "Surfing Shoe", *The Shoe in Sport*, 1989, (Translation of a book published in Germany in 1987), pp 106-110.
 Runner's World, "Spring Shoe Survey", pp 45-74, Apr. 1989.
 Footwear News, vol., 45, No. 5, Nike Advertisement 1989.
 Nike Spring Catalog 1989 pp 62-63.
 Prince Cross-Sport 1989.
 Adidas Catalog 1989.
 Adidas Spring Catalog 1989.
 Adidas Autumn Catalog 1989.
 Nike Shoe, men's cross-training Model "Air Trainer SC" 1989.
 Nike shoe, men's cross-training Model << Air Trainer TW >> 1989.
 Areblad et al., << Three-Dimensional Measurement of Rearfoot Motion During Running >> *Journal of Biomechanics*, vol., 23, pp 933-940 (1990).
 Cavanagh et al., "Biomechanics of Distance Running", Human Kinetics Books, pp 155-164 1990.
 K-Swiss Catalog, Fall 1991.
 Adidas shoe, Model << Water Competition >> 1980.
 Adidas shoe, Model << Tauern >> 1986.
 Saucony Spot-bilt shoe, *The Complete Handbook of Athletic Footwear*, pp 332, 1987.
 Puma basketball shoe, *The Complete Handbook of Athletic Footwear*, pp 315, 1987.
 Adidas shoe, Model, << Indoor Pro >> 1987.
 Fineagan, "Comparison of the Effects of a Running Shoe and A Racing Flat on the Lower Extremity Biomechanical Alignment of Runners", *Journal of the American Physical Therapy Association*, vol., 68, No. 5, p 806 (1988).
 Nike shoe, Model << Zoom Street Leather >> 1988.
 Nike shoe, Model, << Leather Cortez® >>, 1988.
 Nike shoe, Model << Air Revolution >> #15075, 1988.
 Nike shoe, Model "Air Force" #1978, 1988.
 Nike shoe, Model << Air Flow >> #718, 1988.
 Nike shoe, Model "Air" 190 1553, 1988.
 Nike shoe, Model << Air >>, #13213 1988.
 Nike shoe, Model << Air >>, #4183, 1988.
 Adidas shoe Model "Skin Racer" 1988.
 Adidas shoe, Model <<Tennis Comfort >> 1988.
 Palamarchuk et al., "In shoe Casting Technique for Specialized Sports Shoes", *Journal of the America, Podiatric Medical Association*, vol. 79, No. 9, pp 462-465 1989.
 Adidas shoe, Model "Torsion Grand Slam Indoor", 1989.
 Adidas shoe, Model << Torsion ZX 9020 S >> 1989.
 Adidas shoe, Model << Torison Special HI >> 1989.
 Adidas Catalog 1990.
 Adidas' First Supplemental Responses to Interrogatory No. 1.
 Complaint, *Anatomic Research, Inc., and Frampton E. Ellis v. adidas America, Inc.* Civil Action No. 01-1781-A.
 Answer and Counterclaim of Defendant *adidas America, Inc., Anatomic Research, Inc. and Frampton E. Ellis v. adidas America, Inc.* Civil Action No. 01-1781-A dated Dec. 14, 2001.
 Complaint, *Anatomic Research, Inc. v. adidas America, Inc. Adidas Salomon North America, Inc. Adidas Sales, Inc. And adidas Promotional Retail Operations, Inc.* Civil Action No. 2:01cv960.
 Answer and Counterclaim, *Anatomic Research, Inc. v. adidas America, Inc. Adidas Salomon North America, Inc. Adidas Sales, Inc. and adidas Promotional Retail Operations, Inc.* Civil Action No. 2 :cv960 dated Jan. 14, 2002.
 Adidas America, Inc. v. Anatomic Research, Inc. and Frampton E. Ellis, III, *adidas America, Inc.'s Responses to Defendants' First Set of Interrogatories* dated Jan. 28, 2002.

* cited by examiner

FIG. 1

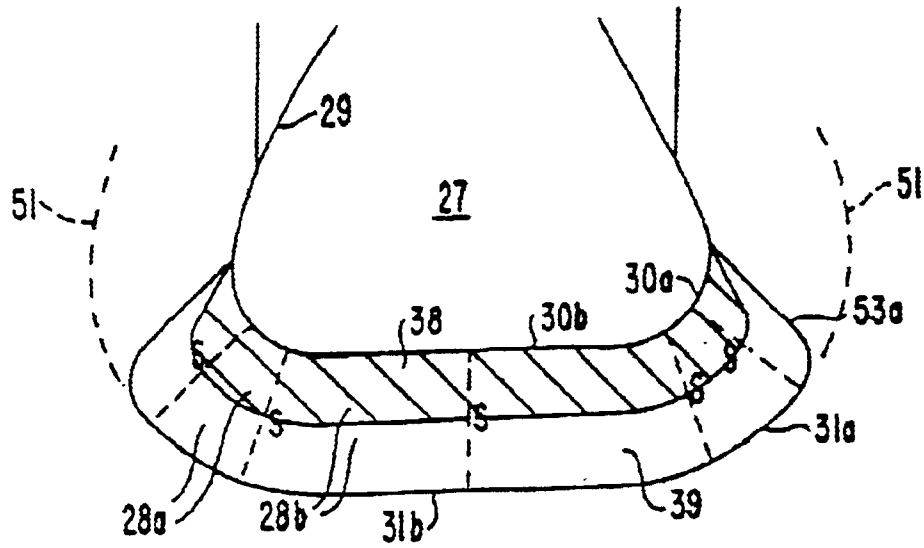

FIG. 2

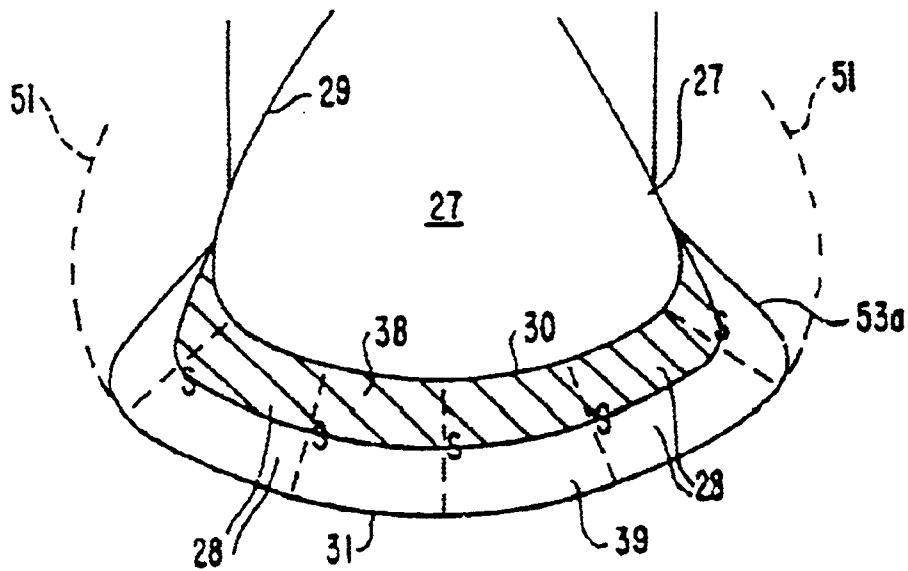

FIG. 3A

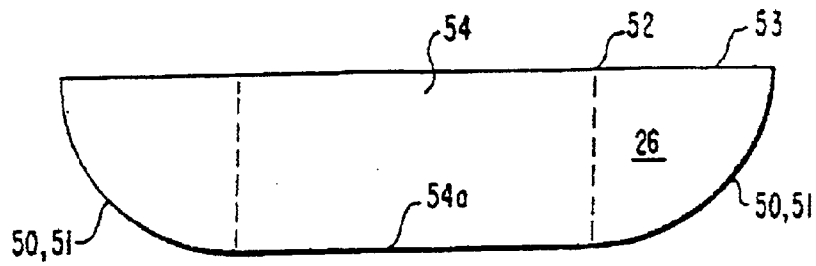

FIG. 3B

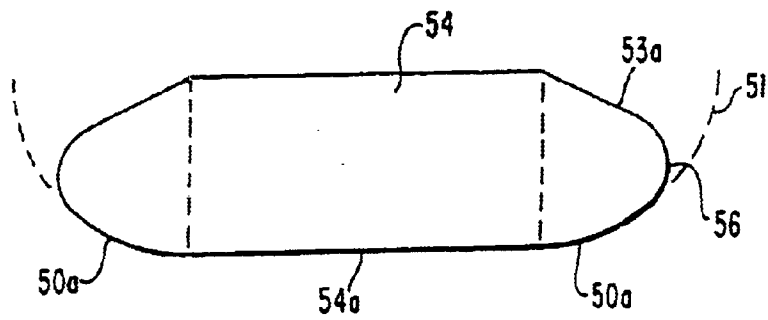

FIG. 3C

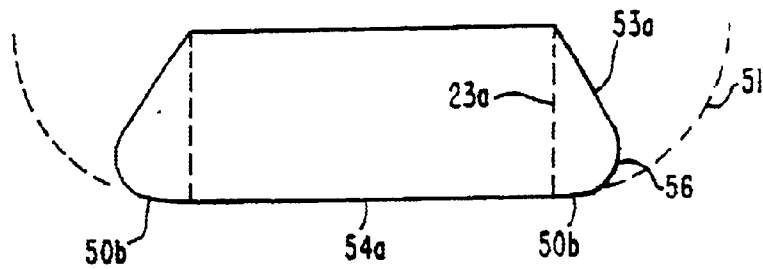

FIG. 4

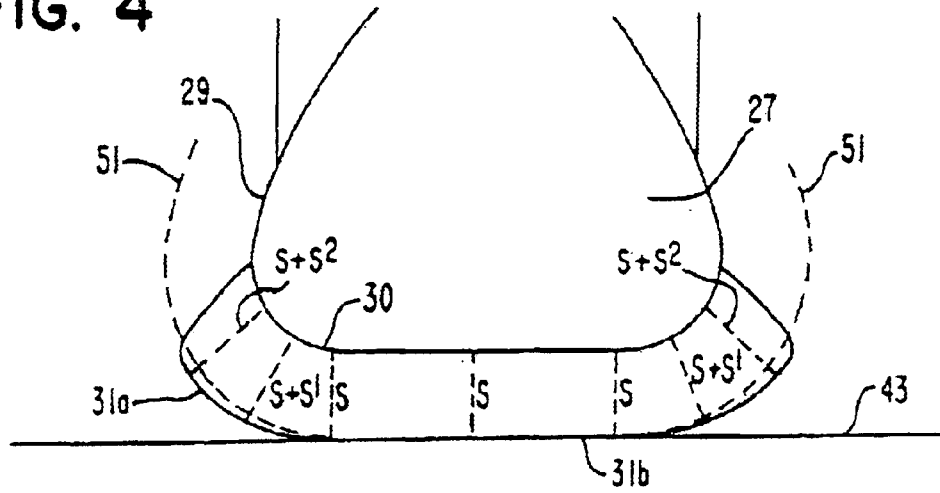

FIG. 6

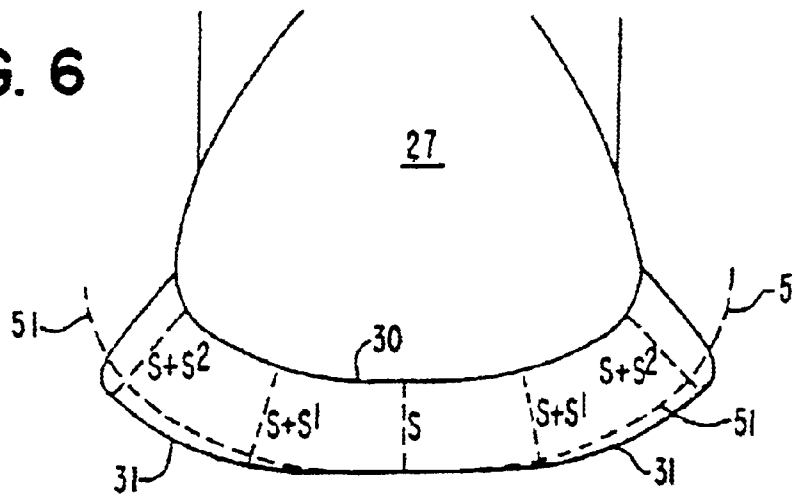

FIG. 7

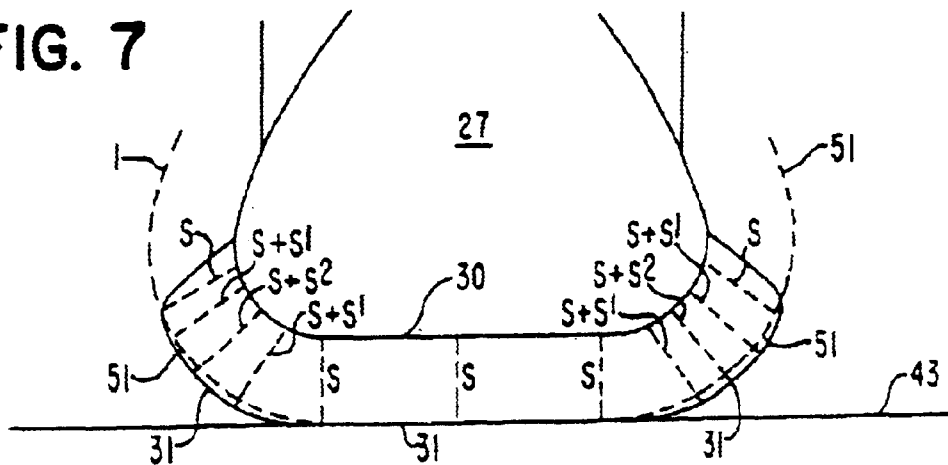

FIG. 5

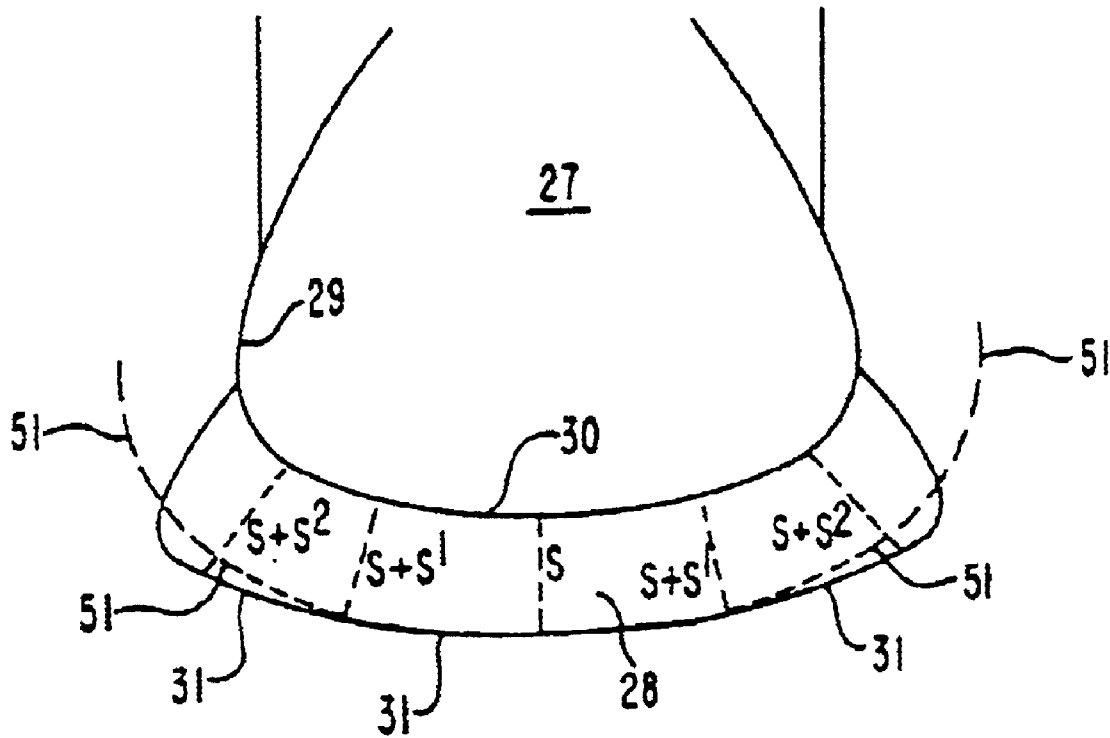

FIG. 8

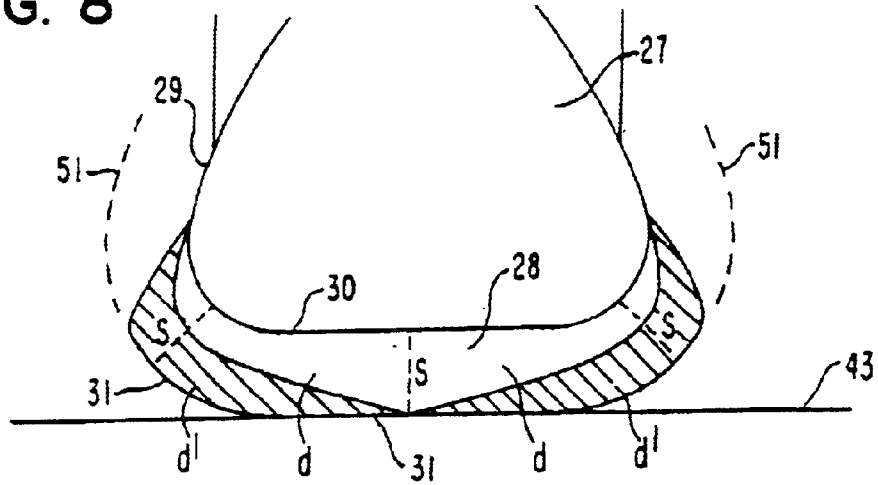

FIG. 9

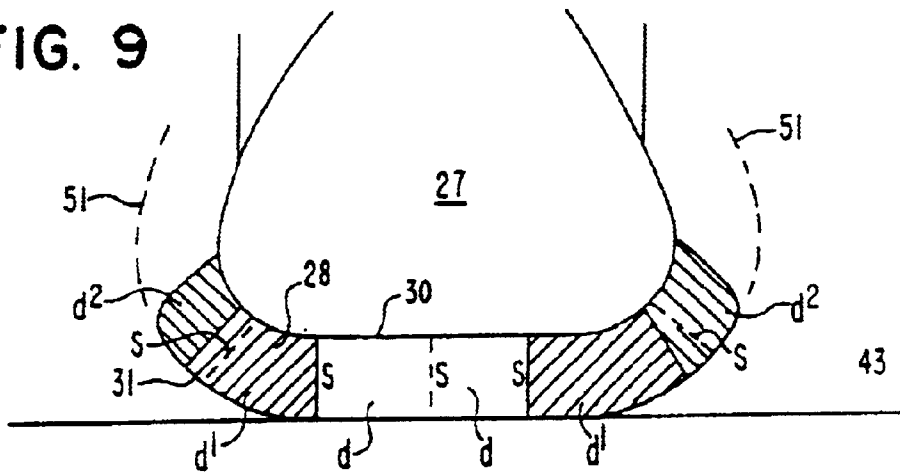

FIG. 10

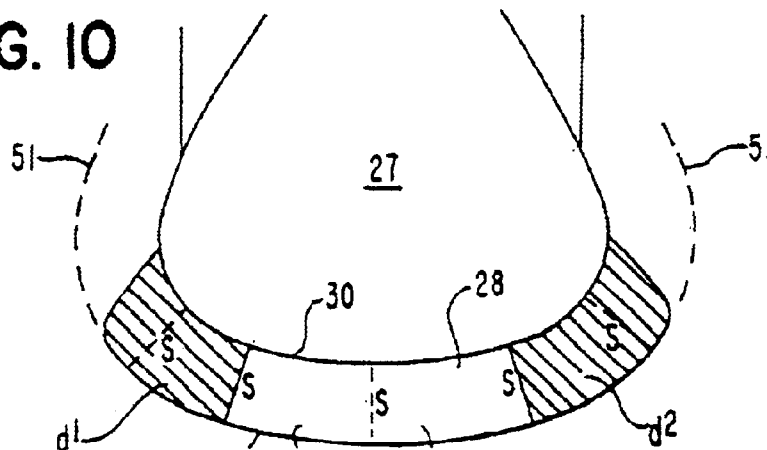

FIG. II

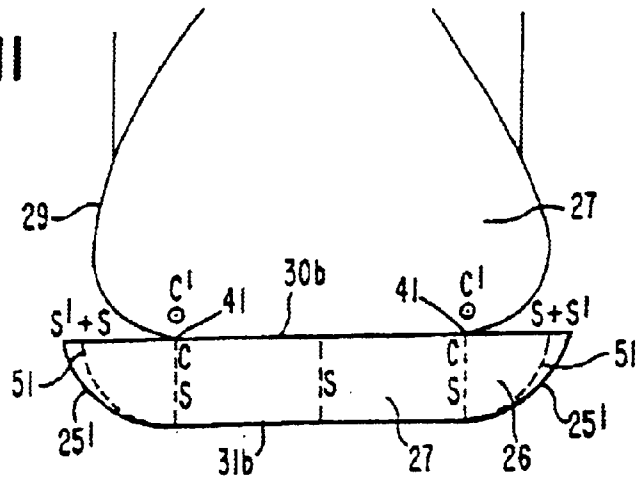

FIG. 12

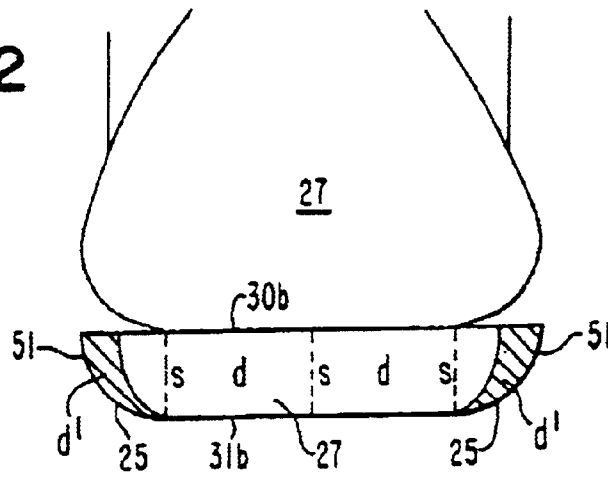

FIG. 13

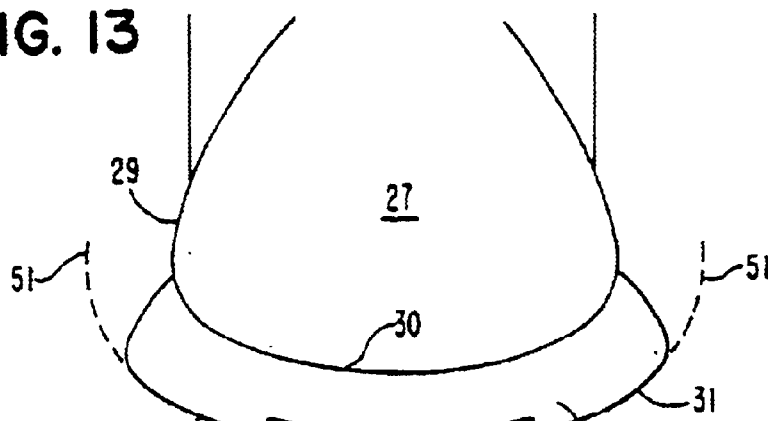

FIG. 14A

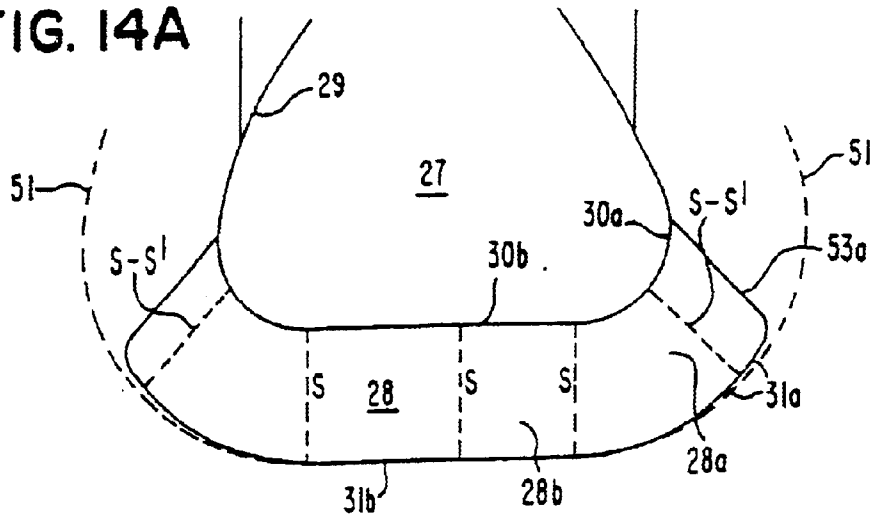

FIG. 14B

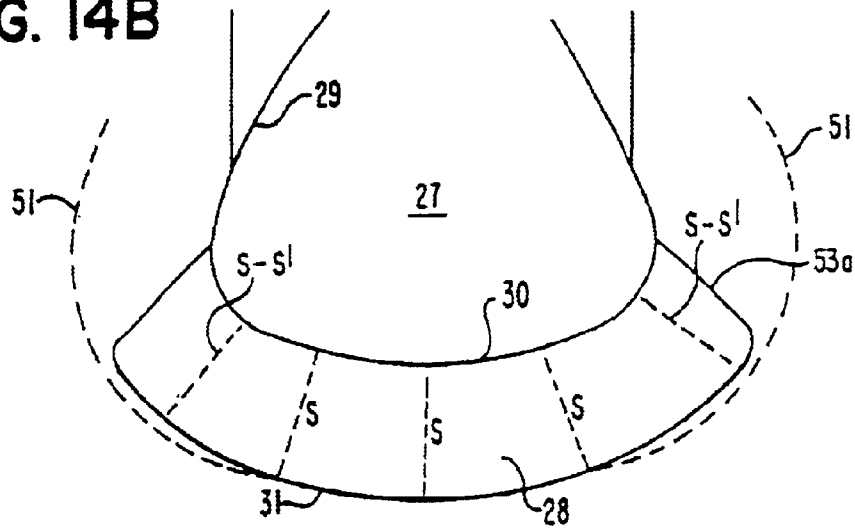

FIG. 14C

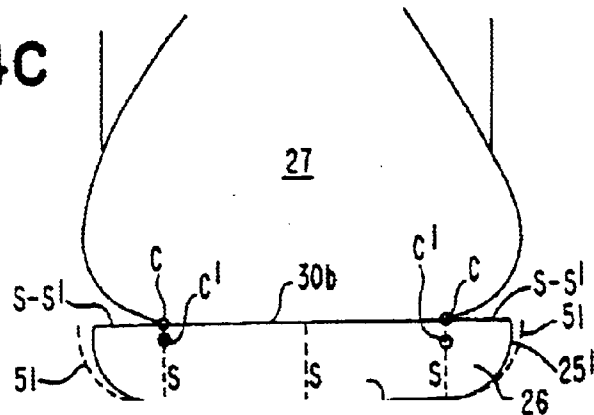

FIG. 15A

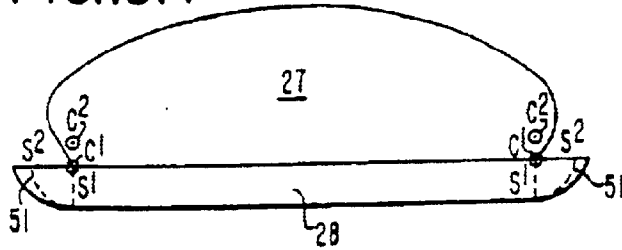

FIG. 15D

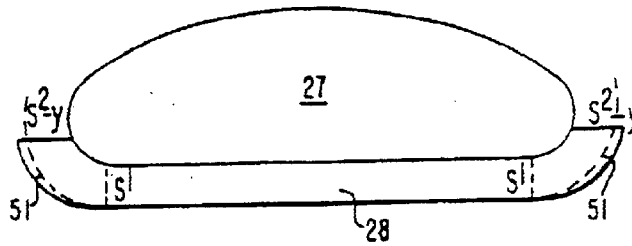

FIG. 15B

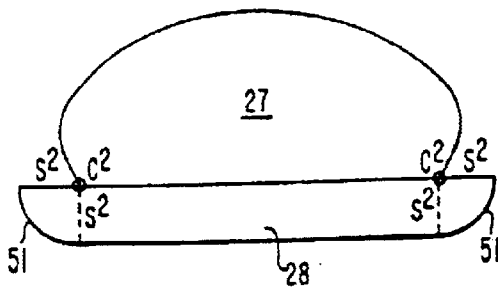

FIG. 15E

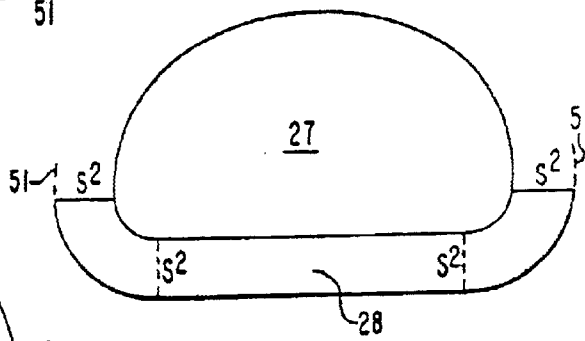

FIG. 15C

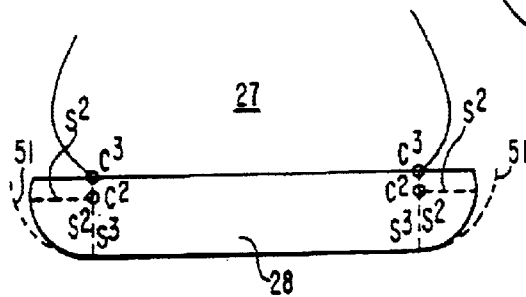
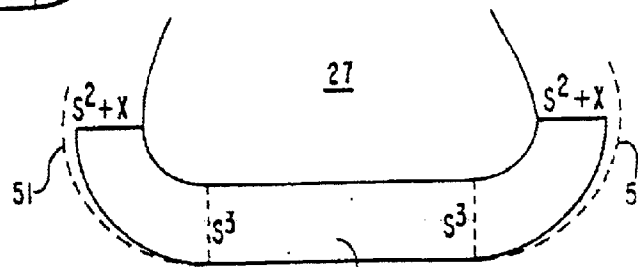

FIG. 15F



**CORRECTIVE SHOE SOLE STRUCTURES
USING A CONTOUR GREATER THAN THE
THEORETICALLY IDEAL STABILITY
PLANE**

**CROSS-REFERENCE TO RELATED
APPLICATIONS**

The present application is a continuation of U.S. application Ser. No. 08/482,838 filed Jun. 7, 1995 now U.S. Pat. No. 6,675,498; which is a continuation of U.S. application Ser. No. 08/452,490 filed, May 30, 1995 now U.S. Pat. No. 6,360,453, which is a continuation of U.S. application Ser. No. 08/142,120, filed Oct. 28, 1993, now abandoned, which is a continuation of U.S. application Ser. No. 07/830,747, filed Feb. 7, 1992, now abandoned, which is a continuation of U.S. application Ser. No. 07/416,478, filed Oct. 3, 1989, now abandoned; and U.S. application Ser. No. 08/482,838 filed Jun. 7, 1995 is a continuation of U.S. application Ser. No. 08/162,962, filed Dec. 8, 1993, now U.S. Pat. No. 5,544,429, which is a continuation of U.S. application Ser. No. 07/930,469, filed Aug. 20, 1992, now U.S. Pat. No. 5,317,819, which is a continuation of U.S. application Ser. No. 07/239,667, filed Sep. 2, 1988, now abandoned, which is a continuation-in-part of U.S. application Ser. No. 07/492,360, filed Mar. 9, 1990, now U.S. Pat. No. 4,989,349, which is a continuation of U.S. application Ser. No. 07/219,387, filed Jul. 15, 1988, now abandoned each of which is incorporated herein by reference in its entirety.

BACKGROUND OF THE INVENTION

This invention relates generally to the structure of shoes. More specifically, this invention relates to the structure of running shoes. Still more particularly, this invention relates to variations in the structure of such shoes having a sole contour which follows a theoretically ideal stability plane as a basic concept, but which deviates therefrom outwardly, to provide greater than natural stability. Still more particularly, this invention relates to the use of structures approximating, but increasing beyond, a theoretically ideal stability plane to provide greater than natural stability for an individual whose natural foot and ankle biomechanical functioning have been degraded by a lifetime use of flawed existing shoes.

Existing running shoes are unnecessarily unsafe. They seriously disrupt natural human biomechanics. The resulting unnatural foot and ankle motion leads to what are abnormally high levels of running injuries.

Proof of the unnatural effect of shoes has come quite unexpectedly from the discovery that, at the extreme end of its normal range of motion, the unshod bare foot is naturally stable, almost unsprainable, while the foot equipped with any shoe, athletic or otherwise, is artificially unstable and abnormally prone to ankle sprains. Consequently, ordinary ankle sprains must be viewed as largely an unnatural phenomena, even though fairly common. Compelling evidence demonstrates that the stability of bare feet is entirely different from the stability of shoe-equipped feet.

The underlying cause of the universal instability of shoes is a critical but correctable design flaw. That hidden flaw, so deeply ingrained in existing shoe designs, is so extraordinarily fundamental that it has remained unnoticed until now. The flaw is revealed by a novel new biomechanical test, one that is unprecedented in its simplicity. The test simulates a lateral ankle sprain while standing stationary. It is easy enough to be duplicated and verified by anyone; it only takes a few minutes and requires no scientific equipment or expertise.

The simplicity of the test belies its surprisingly convincing results. It demonstrates an obvious difference in stability between a bare foot and a running shoe, a difference so unexpectedly huge that it makes an apparently subjective test clearly objective instead. The test proves beyond doubt that all existing shoes are unsafely unstable.

The broader implications of this uniquely unambiguous discovery are potentially far-reaching. The same fundamental flaw in existing shoes that is glaringly exposed by the new test also appears to be the major cause of chronic overuse injuries, which are unusually common in running, as well as other sport injuries. It causes the chronic injuries in the same way it causes ankle sprains; that is, by seriously disrupting natural foot and ankle biomechanics.

The applicant has introduced into the art the concept of a theoretically ideal stability plane as a structural basis for shoe sole designs. That concept as implemented into shoes such as street shoes and athletic shoes is presented in pending U.S. applications Ser. Nos. 07/219,387, filed on Jul. 15, 1988; 07/239,667, filed on Sep. 2, 1988; and 07/400,714, filed on Aug. 30, 1989, as well as in PCT Application No. PCT/US89/03076 filed on Jul. 14, 1989. The purpose of the theoretically ideal stability plane as described in these applications was primarily to provide a neutral design that allows for natural foot and ankle biomechanics as close as possible to that between the foot and the ground, and to avoid the serious interference with natural foot and ankle biomechanics inherent in existing shoes.

This new invention is a modification of the inventions disclosed and claimed in the earlier application and develops the application of the concept of the theoretically ideal stability plane to other shoe structures. As such, it presents certain structural ideas which deviate outwardly from the theoretically ideal stability plane to compensate for faulty foot biomechanics caused by the major flaw in existing shoe designs identified in the earlier patent applications.

The shoe sole designs in this application are based on a recognition that lifetime use of existing shoes, the unnatural design of which is innately and seriously flawed, has produced actual structural changes in the human foot and ankle. Existing shoes thereby have altered natural human biomechanics in many, if not most, individuals to an extent that must be compensated for in an enhanced and therapeutic design. The continual repetition of serious interference by existing shoes appears to have produced individual biomechanical changes that may be permanent so simply removing the cause is not enough. Treating the residual effect must also be undertaken.

Accordingly, it is a general object of this invention to elaborate upon the application of the principle of the theoretically ideal stability plane to other shoe structures.

It is still another object of this invention to provide a shoe having a sole contour which deviates outwardly in a constructive way from the theoretically ideal stability plane.

It is another object of this invention to provide a sole contour having a shape naturally contoured to the shape of a human foot, but having a shoe sole thickness which increases somewhat beyond the thickness specified by the theoretically ideal stability plane.

It is another object of this invention to provide a naturally contoured shoe sole having a thickness somewhat greater than mandated by the concept of a theoretically ideal stability plane, either through most of the contour of the sole, or at preselected portions of the sole.

It is yet another object of this invention to provide a naturally contoured shoe sole having a thickness which

approximates a theoretically ideal stability plane, but which varies toward either a greater thickness throughout the sole or at spaced portions thereof, or toward a similar but lesser thickness.

These and other objects of the invention will become apparent from a detailed description of the invention which follows taken with the accompanying drawings.

BRIEF SUMMARY OF THE INVENTION

Directed to achieving the aforementioned objects and to overcoming problems with prior art shoes, a shoe according to the invention comprises a sole having at least a portion thereof following approximately the contour of a theoretically ideal stability plane, preferably applied to a naturally contoured shoe sole approximating the contour of a human foot.

In another aspect, the shoe includes a naturally contoured sole structure exhibiting natural deformation which closely parallels the natural deformation of a foot under the same load, and having a contour which approximates, but increases beyond the theoretically ideal stability plane. When the shoe sole thickness is increased beyond the theoretically ideal stability plane, greater than natural stability results; when thickness is decreased, greater than natural motion results.

In a preferred embodiment, such variations are consistent through all frontal plane cross sections so that there are proportionally equal increases to the theoretically ideal stability plane from front to back. In alternative embodiments, the thickness may increase, then decrease at respective adjacent locations, or vary in other thickness sequences.

The thickness variations may be symmetrical on both sides, or asymmetrical, particularly since it may be desirable to provide greater stability for the medial side than the lateral side to compensate for common pronation problems. The variation pattern of the right shoe can vary from that of the left shoe. Variation in shoe sole density or bottom sole tread can also provide reduced but similar effects.

These and other features of the invention will become apparent from the detailed description of the invention which follows.

BRIEF DESCRIPTION OF THE DRAWINGS

FIG. 1 shows, in frontal plane cross section at the heel portion of a shoe, the applicant's prior invention of a shoe sole with naturally contoured sides based on a theoretically ideal stability plane.

FIG. 2 shows, again in frontal plane cross section, the most general case of the applicant's prior invention, a fully contoured shoe sole that follows the natural contour of the bottom of the foot as well as its sides, also based on the theoretically ideal stability plane.

FIG. 3, as seen in FIGS. 3A to 3C in frontal plane cross section at the heel, shows the applicant's prior invention for conventional shoes, a quadrant-sided shoe sole, based on a theoretically ideal stability plane.

FIG. 4 shows a frontal plane cross section at the heel portion of a shoe with naturally contoured sides like those of FIG. 1, wherein a portion of the shoe sole thickness is increased beyond the theoretically ideal stability plane.

FIG. 5 is a view similar to FIG. 4, but of a shoe with fully contoured sides wherein the sole thickness increases with increasing distance from the center line of the ground-engaging portion of the sole.

FIG. 6 is a view similar to FIG. 5 where the fully contoured sole thickness variations are continually increasing on each side.

FIG. 7 is a view similar to FIGS. 4 to 6 wherein the sole thicknesses vary in diverse sequences.

FIG. 8 is a frontal plane cross section showing a density variation in the midsole.

FIG. 9 is a view similar to FIG. 8 wherein the firmest density material is at the outermost edge of the midsole contour.

FIG. 10 is a view similar to FIGS. 8 and 9 showing still another density variation, one which is asymmetrical.

FIG. 11 shows a variation in the thickness of the sole for the quadrant embodiment which is greater than a theoretically ideal stability plane.

FIG. 12 shows a quadrant embodiment as in FIG. 11 wherein the density of the sole varies.

FIG. 13 shows a bottom sole tread design that provides a similar density variation as that in FIG. 10.

FIG. 14 shows embodiments like FIGS. 1 through 3 but wherein a portion of the shoe sole thickness is decreased to less than the theoretically ideal stability plane.

FIG. 15 show embodiments with sides both greater and lesser than the theoretically ideal stability plane.

DETAILED DESCRIPTION OF THE PREFERRED EMBODIMENTS

FIGS. 1, 2, and 3 show frontal plane cross sectional views of a shoe sole according to the applicant's prior inventions based on the theoretically ideal stability plane, taken at about the ankle joint to show the heel section of the shoe. FIGS. 4 through 13 show the same view of the applicant's enhancement of that invention. The reference numerals are like those used in the prior pending applications of the applicant mentioned above and which are incorporated by reference for the sake of completeness of disclosure, if necessary. In the figures, a foot 27 is positioned in a naturally contoured shoe having an upper 21 and a sole 28. The sole includes a heel lift or wedge 38 and combined midsole and outsole 39. The shoe sole normally contacts the ground 43 at about the lower central heel portion thereof, as shown in FIG. 4. The concept of the theoretically ideal stability plane, as developed in the prior applications as noted, defines the plane 51 in terms of a locus of points determined by the thickness(s) of the sole. The thickness(s) of the sole at a particular location is measured by the length of a line extending perpendicular to a line tangent to the sole inner surface at the measured location, all as viewed in a frontal plane cross section of the sole. See, for example, FIGS. 1, 2, and 4-7. This thickness(s) may also be referred to as a "radial thickness" of the shoe sole.

FIG. 1 shows, in a rear cross sectional view, the application of the prior invention showing the inner surface of the shoe sole conforming to the natural contour of the foot and the thickness of the shoe sole remaining constant in the frontal plane, so that the outer surface coincides with the theoretically ideal stability plane.

FIG. 2 shows a fully contoured shoe sole design of the applicant's prior invention that follows the natural contour of all of the foot, the bottom as well as the sides, while retaining a constant shoe sole thickness in the frontal plane.

The fully contoured shoe sole assumes that the resulting slightly rounded bottom when unloaded will deform under load and flatten just as the human foot bottom is slightly rounded unloaded but flattens under load; therefore, shoe

sole material must be of such composition as to allow the natural deformation following that of the foot. The design applies particularly to the heel, but to the rest of the shoe sole as well. By providing the closest match to the natural shape of the foot, the fully contoured design allows the foot to function as naturally as possible. Under load, FIG. 2 would deform by flattening to look essentially like FIG. 1. Seen in this light, the naturally contoured side design in FIG. 1 is a more conventional, conservative design that is a special case of the more general fully contoured design in FIG. 2, which is the closest to the natural form of the foot, but the least conventional. The amount of deformation flattening used in the FIG. 1 design, which obviously varies under different loads, is not an essential element of the applicant's invention.

FIGS. 1 and 2 both show in frontal plane cross sections the essential concept underlying this invention, the theoretically ideal stability plane, which is also theoretically ideal for efficient natural motion of all kinds, including running, jogging or walking. FIG. 2 shows the most general case of the invention, the fully contoured design, which conforms to the natural shape of the unloaded foot. For any given individual, the theoretically ideal stability plane 51 is determined, first, by the desired shoe sole thickness(s) in a frontal plane cross section, and, second, by the natural shape of the individual's foot surface 29.

For the special case shown in FIG. 1, the theoretically ideal stability plane for any particular individual (or size average of individuals) is determined, first, by the given frontal plane cross section shoe sole thickness (s); second, by the natural shape of the individual's foot; and, third, by the frontal plane cross section width of the individual's load-bearing footprint 30b, which is defined as the upper surface of the shoe sole that is in physical contact with and supports the human foot sole.

The theoretically ideal stability plane for the special case is composed conceptually of two parts. Shown in FIG. 1, the first part is a line segment 31b of equal length and parallel to line 30b at a constant distance(s) equal to shoe sole thickness. This corresponds to a conventional shoe sole directly underneath the human foot, and also corresponds to the flattened portion of the bottom of the load-bearing foot sole 28b. The second part is the naturally contoured stability side outer edge 31a located at each side of the first part, line segment 31b. Each point on the contoured side outer edge 31a is located at a distance which is exactly shoe sole thickness(s) from the closest point on the contoured side inner edge 30a.

In summary, the theoretically ideal stability plane is the essence of this invention because it is used to determine a geometrically precise bottom contour of the shoe sole based on a top contour that conforms to the contour of the foot. This invention specifically claims the exactly determined geometric relationship just described.

It can be stated unequivocally that any shoe sole contour, even of similar contour, that exceeds the theoretically ideal stability plane will restrict natural foot motion, while any less than that plane will degrade natural stability, in direct proportion to the amount of the deviation. The theoretical ideal was taken to be that which is closest to natural.

FIG. 3 illustrates in frontal plane cross section another variation of the applicant's prior invention that uses stabilizing quadrants 26 at the outer edge of a conventional shoe sole 28b illustrated generally at the reference numeral 28. The stabilizing quadrants would be abbreviated in actual embodiments.

FIG. 4 illustrates the applicant's new invention of shoe sole side thickness increasing beyond the theoretically ideal stability plane to increase stability somewhat beyond its natural level. The unavoidable trade-off resulting is that natural motion would be restricted somewhat and the weight of the shoe sole would increase somewhat.

FIG. 4 shows a situation wherein the thickness of the sole at each of the opposed sides is thicker at the portions of the sole 31a by a thickness which gradually varies continuously from a thickness(s) through a thickness (s+s1), to a thickness (s+s2). Again, as shown in the figures and noted above, the thickness(s) of the sole at a particular location is measured by the length of a line extending perpendicular to a line tangent to the sole inner surface at the measured location, all as viewed in a frontal plane cross section of the sole. This thickness(s) may also be referred to as a "radial thickness" of the shoe sole.

These designs recognize that lifetime use of existing shoes, the design of which has an inherent flaw that continually disrupts natural human biomechanics, has produced thereby actual structural changes in a human foot and ankle to an extent that must be compensated for. Specifically, one of the most common of the abnormal effects of the inherent existing flaw is a weakening of the long arch of the foot, increasing pronation. These designs therefore modify the applicant's preceding designs to provide greater than natural stability and should be particularly useful to individuals, generally with low arches, prone to pronate excessively, and could be used only on the medial side. Similarly, individuals with high arches and a tendency to over supinate and lateral ankle sprains would also benefit, and the design could be used only on the lateral side. A shoe for the general population that compensates for both weaknesses in the same shoe would incorporate the enhanced stability of the design compensation on both sides.

The new design in FIG. 4, like FIGS. 1 and 2, allows the shoe sole to deform naturally closely paralleling the natural deformation of the barefoot underload; in addition, shoe sole material must be of such composition as to allow the natural deformation following that of the foot.

The new designs retain the essential novel aspect of the earlier designs; namely, contouring the shape of the shoe sole to the shape of the human foot. The difference is that the shoe sole thickness in the frontal plane is allowed to vary rather than remain uniformly constant. More specifically, FIGS. 4, 5, 6, 7, and 11 show, in frontal plane cross sections at the heel, that the shoe sole thickness can increase beyond the theoretically ideal stability plane 51, in order to provide greater than natural stability. Such variations (and the following variations) can be consistent through all frontal plane cross sections, so that there are proportionately equal increases to the theoretically ideal stability plane 51 from the front of the shoe sole to the back, or that the thickness can vary, preferably continuously, from one frontal plane to the next.

The exact amount of the increase in shoe sole thickness beyond the theoretically ideal stability plane is to be determined empirically. Ideally, right and left shoe soles would be custom designed for each individual based on an biomechanical analysis of the extent of his or her foot and ankle disfunction in order to provide an optimal individual correction. If epidemiological studies indicate general corrective patterns for specific categories of individuals or the population as a whole, then mass-produced corrective shoes with soles incorporating contoured sides exceeding the theoretically ideal stability plane would be possible. It is

expected that any such mass-produced corrective shoes for the general population would have thicknesses exceeding the theoretically ideal stability plane by an amount up to 5 or 10 percent, while more specific groups or individuals with more severe disfunction could have an empirically demonstrated need for greater corrective thicknesses on the order of up to 25 percent more than the theoretically ideal stability plane. The optimal contour for the increased thickness may also be determined empirically.

FIG. 5 shows a variation of the enhanced fully contoured design wherein the shoe sole begins to thicken beyond the theoretically ideal stability plane 51 somewhat offset to the sides.

FIG. 6 shows a thickness variation which is symmetrical as in the case of FIG. 4 and 5, but wherein the shoe sole begins to thicken beyond the theoretically ideal stability plane 51 directly underneath the foot heel 27 on about a center line of the shoe sole. In fact, in this case the thickness of the shoe sole is the same as the theoretically ideal stability plane only at that beginning point underneath the upright foot. For the applicant's new invention where the shoe sole thickness varies, the theoretically ideal stability plane is determined by the least thickness in the shoe sole's direct load-bearing portion meaning that portion with direct tread contact on the ground; the outer edge or periphery of the shoe sole is obviously excluded, since the thickness there always decreases to zero. Note that the capability to deform naturally of the applicant's design may make some portions of the shoe sole load-bearing when they are actually under a load, especially walking or running, even though they might not appear to be when not under a load.

FIG. 7 shows that the thickness can also increase and then decrease; other thickness variation sequences are also possible. The variation in side contour thickness in the new invention can be either symmetrical on both sides or asymmetrical, particularly with the medial side providing more stability than the lateral side, although many other asymmetrical variations are possible, and the pattern of the right foot can vary from that of the left foot.

FIGS. 8, 9, 10 and 12 show that similar variations in shoe midsole (other portions of the shoe sole area not shown) density can provide similar but reduced effects to the variations in shoe sole thickness described previously in FIGS. 4 through 7. The major advantage of this approach is that the structural theoretically ideal stability plane is retained, so that naturally optimal stability and efficient motion are retained to the maximum extent possible.

The forms of dual and tri-density midsoles shown in the figures are extremely common in the current art of running shoes, and any number of densities are theoretically possible, although an angled alternation of just two densities like that shown in FIG. 8 provides continually changing composite density. However, the applicant's prior invention did not prefer multi-densities in the midsole, since only a uniform density provides a neutral shoe sole design that does not interfere with natural foot and ankle biomechanics in the way that multi-density shoe soles do, which is by providing different amounts of support to different parts of the foot; it did not, of course, preclude such multi-density midsoles. In these figures, the density of the sole material designated by the legend (d1) is firmer than (d) while (d2) is the firmest of the three representative densities shown. In FIG. 8, a dual density sole is shown, with (d) having the less firm density.

It should be noted that shoe soles using a combination both of sole thicknesses greater than the theoretically ideal stability plane and of midsole densities variations like those just described are also possible but not shown.

FIG. 13 shows a bottom sole tread design that provides about the same overall shoe sole density variation as that provided in FIG. 10 by midsole density variation. The less supporting tread there is under any particular portion of the shoe sole, the less effective overall shoe sole density there is, since the midsole above that portion will deform more easily than if it were fully supported.

FIG. 14 shows embodiments like those in FIGS. 4 through 13 but wherein a portion of the shoe sole thickness is decreased to less than the theoretically ideal stability plane. It is anticipated that some individuals with foot and ankle biomechanics that have been degraded by existing shoes may benefit from such embodiments, which would provide less than natural stability but greater freedom of motion, and less shoe sole weight add bulk. In particular, it is anticipated that individuals with overly rigid feet, those with restricted range of motion, and those tending to over-supinate may benefit from the FIG. 14 embodiments. Even more particularly, it is expected that the invention will benefit individuals with significant bilateral foot function asymmetry: namely, a tendency toward pronation on one foot and supination on the other foot. Consequently, it is anticipated that this embodiment would be used only on the shoe sole of the supinating foot, and on the inside portion only, possibly only a portion thereof. It is expected that the range less than the theoretically ideal stability plane would be a maximum of about five to ten percent, though a maximum of up to twenty-five percent may be beneficial to some individuals.

FIG. 14A shows an embodiment like FIGS. 4 and 7, but with naturally contoured sides less than the theoretically ideal stability plane. FIG. 14B shows an embodiment like the fully contoured design in FIGS. 5 and 6, but with a shoe sole thickness decreasing with increasing distance from the center portion of the sole. FIG. 14C shows an embodiment like the quadrant-sided design of FIG. 11, but with the quadrant sides increasingly reduced from the theoretically ideal stability plane.

The lesser-sided design of FIG. 14 would also apply to the FIGS. 8 through 10 and 12 density variation approach and to the FIG. 13 approach using tread design to approximate density variation.

FIG. 15 A-C show, in cross sections similar to those in pending U.S. application Ser. No. 07/219,387, that with the quadrant-sided design of FIGS. 3, 11, 12 and 14C that it is possible to have shoe sole sides that are both greater and lesser than the theoretically ideal stability plane in the same shoe. The radius of an intermediate shoe sole thickness, taken at (S^2) at the base of the fifth metatarsal in FIG. 15B, is maintained constant throughout the quadrant sides of the shoe sole, including both the heel, FIG. 15C, and the forefoot, FIG. 15A, so that the side thickness is less than the theoretically ideal stability plane at the heel and more at the forefoot. Though possible, this is not a preferred approach.

The same approach can be applied to the naturally contoured sides or fully contoured designs described in FIGS. 1, 2, 4 through 10 and 13, but it is also not preferred. In addition, is shown in FIGS. 15D-F, in cross sections similar to those in pending U.S. application Ser. No. 07/239,667, it is possible to have shoe sole sides that are both greater and lesser than the theoretically ideal stability plane in the same shoe, like FIGS. 15A-C, but wherein the side thickness (or radius) is neither constant like FIGS. 15A-C or varying directly with shoe sole thickness, like in the applicant's pending applications, but instead varying quite indirectly with shoe sole thickness. As shown in FIGS. 15D-F, the shoe sole side thickness varies from somewhat less than

shoe sole thickness at the heel to somewhat more at the forefoot. This approach, though possible, is again not preferred, and can be applied to the quadrant sided design, but is not preferred there either.

The foregoing shoe designs meet the objectives of this invention as stated above. However, it will clearly be understood by those skilled in the art that the foregoing description has been made in terms of the preferred embodiments and various changes and modifications may be made without departing from the scope of the present invention which is to be defined by the appended claims.

What is claimed:

1. An athletic shoe sole for a shoe, comprising:
 - a shoe outer sole and a shoe midsole;
 - a sole heel area underneath a heel of an intended wearer's foot, a midsole inner surface for supporting a sole of said intended wearer's foot, and a midsole outer surface;
 - a midsole central part, a midsole medial side portion and a midsole lateral side portion, as viewed in a shoe sole frontal plane cross-section in the heel area during an unloaded, upright shoe condition;
 - the midsole lateral side portion formed by that part of the midsole located lateral of a straight vertical line extending through a sidemost extent of the midsole inner surface of a lateral side of the shoe, as viewed in the heel area frontal plane cross-section during an unloaded, upright shoe condition;
 - the midsole medial side portion formed by that part of the midsole located medial of a straight vertical line extending through a sidemost extent of the midsole inner surface of a medial side of the shoe, as viewed in the heel area frontal plane cross-section during an unloaded, upright shoe condition;
 - a midsole central part of the athletic shoe sole formed by that part of the midsole located between the midsole lateral side portion and the midsole medial side portion, as viewed in the heel area frontal plane cross-section during and unloaded, upright shoe condition;
 - said midsole outer surface of said midsole central part comprising a concavely rounded portion, the concavity existing with respect to an inner section of the midsole located directly adjacent to the concavely rounded portion of the midsole outer surface, all as viewed in the heel area frontal plane cross-section during an unloaded, upright shoe condition;
 - said midsole inner surface of said midsole central part comprising a convexly rounded portion at least through a midpoint of the midsole inner surface of the midsole central part, the convexity existing with respect to a section of the midsole directly adjacent to the convexly rounded portion of the midsole inner surface, all as viewed in the heel area frontal plane cross-section during an unloaded, upright shoe condition; at least a portion of the midsole located between said concavely rounded portion of the midsole outer surface and the convexly rounded portion of the midsole inner surface has a substantially uniform radial thickness, as viewed in a frontal plane cross-section when the shoe sole is upright and in an unloaded condition; and
 - said shoe midsole comprises midsole material of varying firmness.
2. The shoe sole as set forth in claim 1, wherein said central part includes a section having at least two material layers, each layer composed of a midsole material of dif-

ferent firmness, as viewed in the shoe sole frontal plane cross section during an unloaded, upright shoe condition.

3. The shoe sole as set forth in claim 1, wherein a sole firmness of the sole medial side is different from a sole firmness of the sole lateral side, as viewed in the shoe sole frontal plane cross section during an unloaded, upright shoe condition.

4. The shoe sole as set forth in claim 1, wherein the sole central part has a varying radial thickness, as viewed in the shoe sole frontal plane during an upright, unloaded shoe condition.

5. The shoe sole as set forth in claim 1, wherein the concavely rounded midsole portion with substantially uniform radial thickness extends through a lowermost section of the midsole central part, as viewed in the shoe sole frontal plane during an unloaded, upright shoe condition.

6. The shoe sole as set forth in claim 1, wherein the concavely rounded midsole portion with substantially uniform radial thickness extends from the midsole central part into one of the midsole lateral and medial sides, as viewed in the shoe sole frontal plane during an unloaded, upright shoe condition.

7. The shoe sole as set forth in claim 1, wherein the concavely rounded midsole portion with substantially uniform radial thickness extends from the midsole central part continuously through a sidemost extent of one of the midsole lateral and medial sides, as viewed in the shoe sole frontal plane during an unloaded, upright shoe condition.

8. The shoe sole according to claim 1 wherein the concavely rounded midsole portion with substantially uniform radial thickness extends from the midsole central part to above the lowest point on the midsole inner surface on one of the midsole lateral and medial side portions, as viewed in the shoe sole frontal plane cross section during an unloaded, upright shoe condition.

9. The shoe sole according to claim 1, wherein the concavely rounded midsole portion with substantially uniform radial thickness extends through a midpoint of the midsole central part, as viewed in the shoe sole frontal plane during an unloaded, upright shoe condition.

10. The shoe sole according to claim 1, wherein the midsole includes three different materials, each with a different firmness.

11. The shoe sole according to claim 1, wherein the midsole includes two different materials, one material having a greater radial thickness in one of the lateral and medial sides than a radial thickness in the sole central part, as viewed in the shoe sole frontal plane during an unloaded, upright shoe condition.

12. The shoe sole according to claim 1, wherein the concavely rounded midsole portion with substantially uniform radial thickness extends to the location of one of said vertical lines, as viewed in the shoe sole frontal plane during an unloaded, upright shoe condition.

13. The shoe sole according to claim 12, wherein the concavely rounded midsole portion with substantially uniform radial thickness extends to the location of the other of said vertical lines, as viewed in the shoe sole frontal plane during an unloaded, upright shoe condition.

14. The shoe sole according to claim 1, wherein the midsole extends into at least one of the lateral and medial sides to above a lowest point of the sole inner surface, as viewed in the shoe sole frontal plane during an unloaded, upright shoe condition.

15. The shoe sole according to claim 1, wherein the sole includes concavely rounded midsole portions with substantially uniform radial thickness located at both the midsole

11

lateral side and the midsole medial side, as viewed in the shoe sole frontal plane during an unloaded, upright shoe condition, the concavity existing with respect to an intended wearer's foot location in the shoe.

16. The shoe sole as set forth in claim 6, wherein the concavely rounded midsole portion with substantially uniform radial thickness extends from the midsole central part into both of the midsole lateral and medial side portions, as viewed in the heel area frontal plane cross-section during an unloaded, upright shoe condition.

17. The shoe sole as set forth in claim 7, wherein the concavely rounded midsole portion with substantially uniform radial thickness extends from the midsole central part continuously through sidemost extents of both of the midsole lateral and medial side portions, as viewed in the heel area frontal plane cross-section during an unloaded, upright shoe condition.

18. The shoe sole as set forth in claim 8, wherein the concavely rounded midsole portion with substantially uniform radial thickness extends from the midsole central part to above the lowest point on the midsole inner surface of both of the midsole lateral and medial side portions, as viewed in the heel area frontal plane cross-section during an unloaded, upright shoe condition.

19. The shoe sole as set forth in claim 1, wherein the radial thickness of at least one of the midsole lateral and medial side portions decreases gradually and continuously from

12

above a sidemost extent of at least one of the lateral and medial side portions to an uppermost point of at least one of the lateral and medial side portions, as viewed in the heel area frontal plane cross-section during an unloaded, upright shoe condition.

20. The shoe sole according to claim 11, wherein one of the two different midsole materials has a greater radial thickness in the midsole central part than a radial thickness in one of the lateral and medial side portions, as viewed in the heel area frontal plane cross-section during an unloaded, upright shoe condition.

21. The shoe sole according to claim 14, wherein the midsole extends into both the lateral and medial sides to above a lowest point of the sole inner surface, as viewed in the shoe sole frontal plane during an unloaded, upright shoe condition.

22. The shoe sole according to claim 19, wherein the radial thickness of at least one of the midsole lateral and medial side portions decreases gradually and continuously from above a sidemost extent of at least one of the lateral and medial side portions to an uppermost point of at least one of the lateral and medial side portions, as viewed in the heel area frontal plane cross-section during an unloaded, upright shoe condition.

* * * * *